



TIM CAMPBELL 800-400-7500

Item # _____

Job _____

METRO MOBILE®
HEAVY-DUTY
PLATFORM DOLLIES

- **Material:** 14-gauge, high-strength, natural finish aluminum.
- **Rugged:** Aircraft-riveted construction throughout . . . means additional strength.
- **Heavy-Duty**
- **Easily Cleaned**
- **Removable Handle**
- **A Full Line** to meet your exact requirements.



D23N



METRO MOBILE® HEAVY-DUTY PLATFORM DOLLIES

Specifications

- **Material:** 14-gauge, high-strength, natural finish aluminum.
- **Construction:** Aircraft-riveted construction throughout.
- **Chassis:** Brake-formed, box-shaped chassis with 8-gauge reinforcing corner angle plates.
- **Handle:** 1" (25.4mm) O.D. tubular stainless steel handle, mounted to chassis by handle socket which extends through chassis.
- **Casters:** Two 5" (127mm) B5DN swivel on back — rigid, double ball bearing, ball bearing axle, nickel-plated, donut neoprene-tired, pre-lubricated, bolted through reinforcing plates to bottom of chassis. Two B5DNR on front — same as above, but rigid.

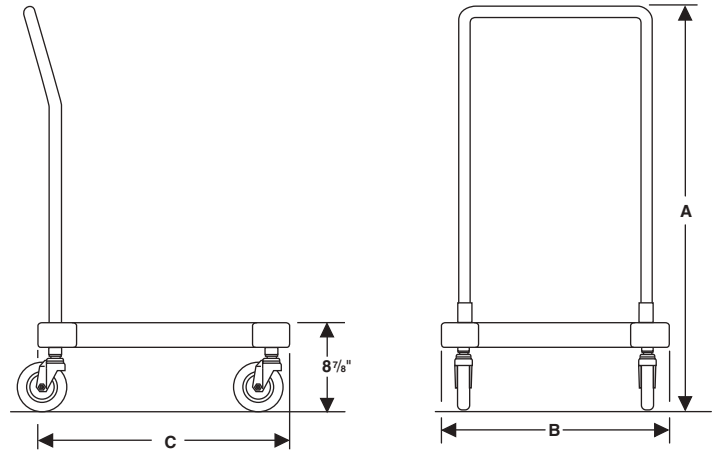

Dimensions

Cat. No.	(A) Height w/ Handle		(B) Width		(C) Length		Platform Area		Platform Height		Approx. Pkd. Wt.	
	(in.)	(mm)	(in.)	(mm)	(in.)	(mm)	(in.)	(mm)	(in.)	(mm)	(lbs.)	(kg)
D22N	39 ¹ / ₈	995	21 ¹ / ₄	540	23 ¹ / ₄	590	21 x 21	530 x 530	8 ⁷ / ₈	225	33	15
D23N	39 ¹ / ₈	995	21 ¹ / ₄	540	34 ¹ / ₄	870	21 x 32	530 x 810	8 ⁷ / ₈	225	36	16
D24N	39 ¹ / ₈	995	21 ¹ / ₄	540	44 ¹ / ₄	1125	21 x 42	530 x 1065	8 ⁷ / ₈	225	38	17

Accessories

Cat. No.

A32	Gray Corner Bumpers
A33	Gray Continuous Bumper
A71	Floor Lock